

CUSTOMER PART No.	CUSTOMER <b>CAN ART STD.</b>	DIE No. <b>EH05684</b>
DESCRIPTION <b>1" x 2" x .062" RECT. TUBE</b>		PROPOSAL No. <b>H-10511</b>

NOTE: BREAK ALL CORNERS WITH 0.015" (.38 MM) RADIUS UNLESS OTHERWISE NOTED. STANDARD TOLERANCES TO APPLY UNLESS OTHERWISE SPECIFIED.

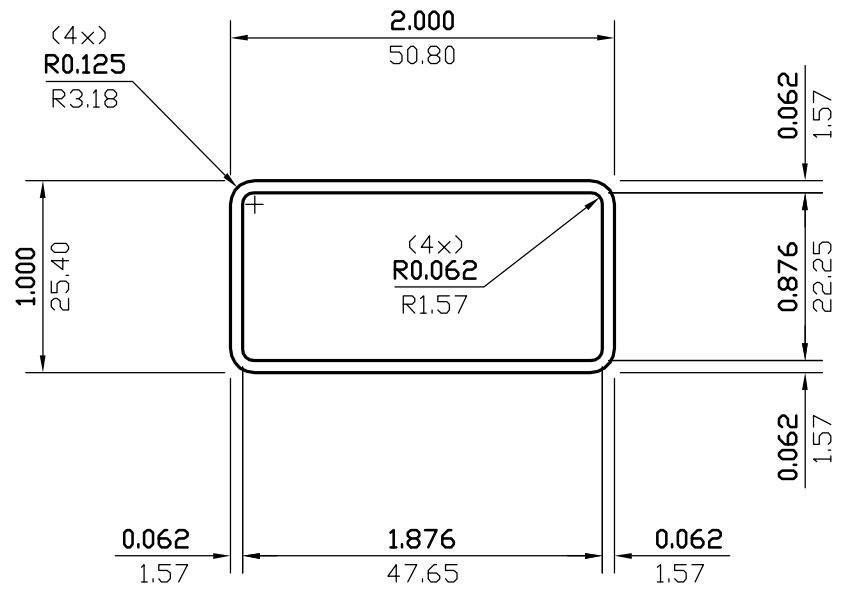

WALL THICKNESS (AS SHOWN)		EXCEPT AS SHOWN	
DATE	REV	DESCRIPTION	BY
EST.AREA	0.347	IN. <sup>2</sup>	EST.AREA 223.557
EST.WT.	0.416	LBS/FT.	EST.WT. 0.619
EST.PER.	11.183	IN.	EST.PER. 284.047
OUT PER.	5.785	IN.	OUT PER. 146.9
C.C.D.	2.136	IN.	C.C.D. 54.254
FACTOR	27	FINISH	M/F
ALLOY & TEMP.	6063		
CKD BY	SCALE	1:1	DWN BY C.P. DATE 11/30/2000

**CAN ART**  
ALUMINUM EXTRUSION INC.

85 PARKSHORE DRIVE  
BRAMPTON, ONT L6T 5M1  
TEL. NO. (905) 791-1464  
FAX NO. (905) 791-9151  
E-MAIL: canart@canart.com

THIS DRAWING IS NOT NECESSARILY A COPY OF YOUR ORIGINAL. PLEASE APPROVE DIMENSIONS AND TOLERANCES INDICATED. CAN ART ASSUMES NO RESPONSIBILITY EITHER TECHNICAL OR LEGAL FOR HAVING THIS SHAPE MADE. THE CUSTOMER AGREES TO FULLY PROTECT CAN ART ALUMINUM FROM CLAIMS OF OTHERS RESULTING FROM THIS SHAPE.

SIGNED: \_\_\_\_\_ DATE: \_\_\_\_\_